

Conventions Used in this Manual	3
Warning and Safety.....	3
Power Supply Capacitors	3
One-Armed Testing	3
Never Work When You Are Tired.....	3
About Fuses	3
Tubes Get Hot	4
Impedance and Load	4
Glow In The Dark	4
Children, Pets and Others	4
Hair and Clothing.....	4
Introduction.....	5
Overview of the Headphone Amplifier.....	5
Familiarizing with the Parts	5
The Passive Parts – Resistors and Capacitors	7
The Tubes – 417A and 5842.....	7
The Transformers.....	7
The Connectors – Headphone jack, RCA jacks, AC Inlet.....	10
The Switches and Fuse Holder with Fuse.....	12
Recommended Tools	13
Internal Layout Preview.....	15
Drilling Your Chassis	15
Chassis Assembly	18
Mechanical Assembly.....	21
Installing the RCA Input Jacks	22
Installing the AC Inlet Connector	23
Installing the Power Switch	23
Installing the Fuse Holder.....	23
Installing the Impedance Switch.....	23
Installing the Headphone Jack	24
Installing the Volume Control	24

Installing the Tube Sockets and Terminal Strip.....	24
Mounting the Transformers	25
How to Attach an Optional Feet	25
Electrical Assembly	26
Wiring the Main Circuit.....	26
Checkpoint	28
Wiring the Front and Back Panel Connectors and Switches	29
Checkpoint	31
Checkpoint	32
Checkpoint	33
Wiring the Power Supply Unit (PSU).....	33
Checkpoint	34

DRAFT

Conventions Used in this Manual

Please familiarize yourself with the conventions used in this manual for better understanding.

- ① The paragraph marked with this symbol is informational and should be read and understood before proceeding.
- The paragraph marked with this symbol is a step that you have to complete. Upon completion, we suggest you mark the box with a check using a pencil to indicate that you have completed such step.
- 👁 The paragraph marked with this symbol means you have to make a visual confirmation of the steps or result.
- 🚫 The paragraph marked with this symbol means you have to stop and take a moment to understand what is written as it could be a warning or safety issue.

Warning and Safety

All tube amps possess lethal voltages and current. They CAN kill you! If you are not qualified to work on an amp, then by all means find and take it to a qualified technician! Better be safe than sorry!!!

Power Supply Capacitors

The filter capacitors in an amp will retain a charge for quite some time after the amp is shut off and unplugged. It is a good idea to make sure your amp is safe to work on. It is best to discharge these capacitors before you begin work. Put a 47K-100k, 5 watts or more on both ends of two alligator clips and put one end of the alligator clip first to ground, then the other to the filter caps themselves. Never short the capacitor terminals directly

One-Armed Testing

When it is time to work on a live circuit, clip one of your meter's test leads to ground, and use only the right hand to probe the circuit, keeping the left hand in your pocket. That way if you DO take a shock, your heart is not in line of the path of least resistance -in one arm and out the other.

Never Work When You Are Tired

Or fatigued, or worse, drunk! When you are in any of these conditions, your reflexes are slower, and you would be more likely to make a fatal mistake. Don't risk it! It's not worth it.

About Fuses

Fuses provide you and the circuit, protection. Never under any circumstance replace a fuse with one with a higher rating or replace a fast-blow type with a slow-blow one. Do not defeat the fuse by using aluminum or thin strands of wire.

Tubes Get Hot

It is always a good idea to let the amplifier cool down for a while before moving it, or messing with the tubes. This way you will avoid some serious burns. Wear welding or oven gloves if you must handle hot tubes!

Impedance and Load

Always follow the rated impedance of your amplifier. Never under any circumstance run the amp without a speaker attached. Use a dummy load if you have to.

Glow In The Dark

In situations that you are going to work with the lights out, so as to see arcing, or to notice the glow on tubes, make sure that before you turn out the lights, plan what you are going to do, know your work area.

Children, Pets and Others

Your workbench/workarea is not the place to let the children or the pets play. The lethal voltages will be even more lethal for them! ALWAYS make sure you unplug your work, and even lock the room when you are away from it. Remember, death IS permanent! You wouldn't let your children or pets play in the middle of the freeway, nor should they around an open chassis.

Hair and Clothing

Both can be good conductors of electricity. Keep them away! They also have a hard time dealing with power tools and soldering irons! While we are on the topic of clothing, wear the right clothes. Shorts can be bad when soldering, or other hot items, wear pants, it could save you some grief. It is not fun to have molten solder splashed on body parts. Pants will also give you that extra margin of safety, if say you are probing the plates of your tubes for voltage, and by some freak of nature, the one you had clipped to ground came loose and hit your leg. That probe is carrying the full potential of what you are probing, which in some cases could be over 700volts!! Sure, the pants probably won't help you here, if the tip pierces them, but it will give you that extra chance! Safety goggles should be worn when using power tools. Yes, this is obvious, but many people tend to neglect this! ALSO, your ears are vital as an amp builder and a musician. If you are going to be playing your new creation at loud volumes (even 5-watt amps can be painfully loud!!), wear earplugs!

Introduction

Thank you for purchasing the AK-100 Headphone Amplifier kit. With proper assembly, this kit will give you many years of musical satisfaction.

Overview of the Headphone Amplifier

This kit is based on the KISS principle and pretty straightforward. It is essentially a low-power amplifier utilizing the Western Electric 417A (and its variant, the 5842) to drive headphones with 16ohms to 300ohms impedance.

Familiarizing with the Parts

This kit is supplied with all parts required for assembly.

When you receive the kit, check the actual parts against the Bill of Materials (BOM) as shown in the table below.

Should you find that there are parts missing, let us know immediately so that we can rectify the situation.

Table 1: Bill Of Materials

<u>Qty</u>	<u>Unit</u>	<u>Description</u>	
<i>Passive</i>			
2	pc	100ohm 2watts	<input type="checkbox"/>
2	pc	220Kohm, 1watt	<input type="checkbox"/>
2	pc	1Kohm, 2 watts	<input type="checkbox"/>
1	pc	ALPS blue	<input type="checkbox"/>
2	pc	220uF 16V Black Gate	<input type="checkbox"/>
3	pc	47uF 450V	<input type="checkbox"/>
4	pc	FR107	<input type="checkbox"/>
<i>Wires</i>			
1	pc	Pre-cut WHITE hookup wire, ends stripped, tinned	<input type="checkbox"/>

AK-100 Kit Assembly Manual

1	pc	Pre-cut RED hookup wire, ends stripped, tinned	<input type="checkbox"/>
1	feet	Black hookup wire, #26	<input type="checkbox"/>
1	feet	Shielded wire, 2 conductor + ground	<input type="checkbox"/>
1	feet	Heatshrink tubes (for Toggle switches)	<input type="checkbox"/>
1	pc	Power cord	<input type="checkbox"/>

Transformers

1	set	power transformer x 1	<input type="checkbox"/>
		output transformer x 2	

Chassis and Mounting

1	set	Chassis	<input type="checkbox"/>
2	pc	RCA jacks	<input type="checkbox"/>
1	pc	Headphone Jack 1/8"	<input type="checkbox"/>
2	pc	Toggle Switch	<input type="checkbox"/>
2	pc	9-pin sockets	<input type="checkbox"/>
1	pc	Knob	<input type="checkbox"/>
1	pc	1A fuse	<input type="checkbox"/>
1	pc	Fuse Holder	<input type="checkbox"/>
1	pc	SOCKET, FREE 3 WAY	<input type="checkbox"/>
1	pc	PLUG, PANEL 3 WAY	<input type="checkbox"/>
1	pc	terminal strip	<input type="checkbox"/>
4	set	hex mounting screw set	<input type="checkbox"/>
		(nut, bolt, washer, locking washer)	

The Passive Parts – Resistors and Capacitors

The supplied resistors are Carbon Film type, in 1 watt and 2 watts power dissipation. Please orient yourself with the values of the resistors.

The kit is supplied with Electrolytic type capacitors for various functions (bypass and filtering).



Figure 1: Capacitors

The capacitor values are clearly marked on their bodies and you should be able to distinguish one from the other. Though small in size, these capacitors are high-quality products from Panasonic.

The Tubes – 417A and 5842

This headphone amplifier can accept both 417A or 5842 variants. The Western Electric 417A, Amperex gold pins 5842, and Raytheon 5842 have been tested on this circuit.

👉 Important: Tubes are not included in the kit. You have to source your own and they can be had for reasonable prices.

The Transformers

The transformers and chokes were custom-wound to our specifications by a transformer manufacturer with over 40 years of experience in the business.

👉 Warning: These transformers are heavy and should be handled with care. They could survive a drop but surely, your toes won't.

There are three transformers – one (1) power transformer and two (2) output transformers. The size of the power transformer is bigger than the output transformers. Please take note of the color coding of the transformer wires.

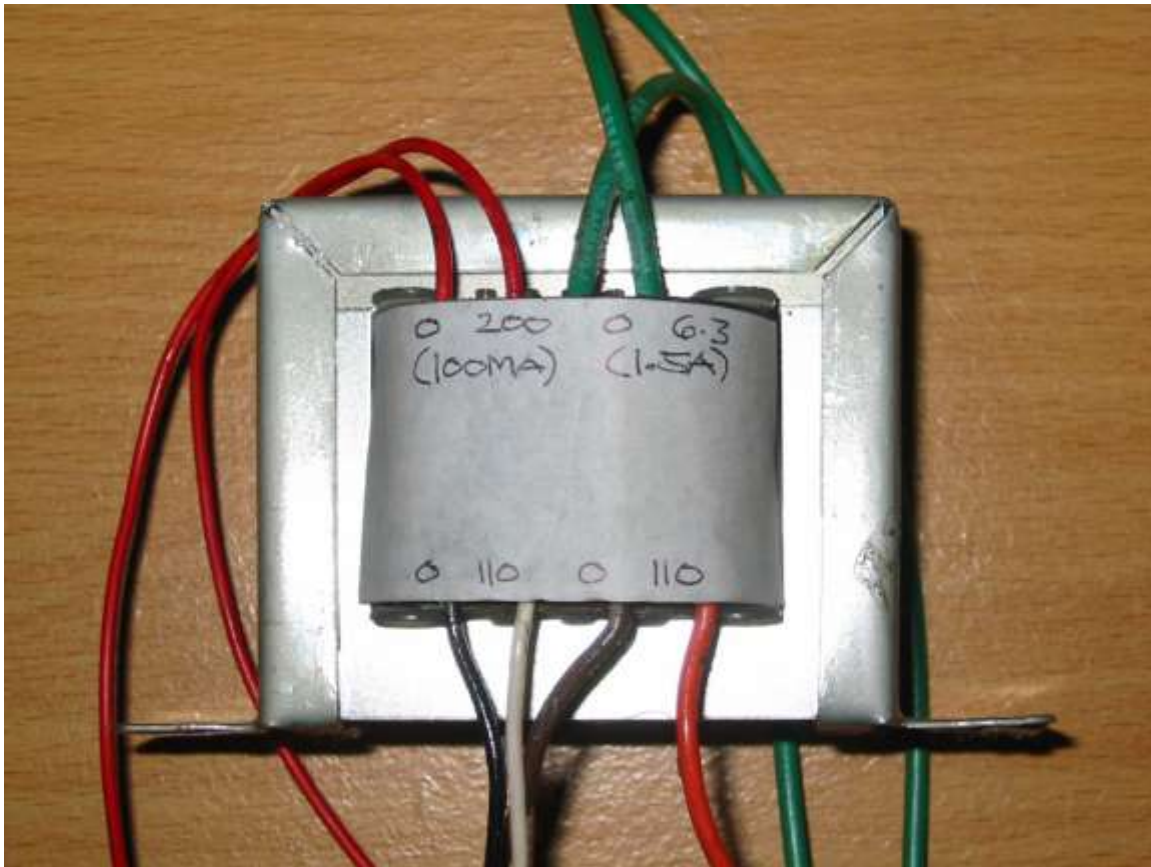

Figure 2: The Power Transformer

Familiarize yourself with the transformer terminal wire color coding.

Please note that the picture may not represent the current terminal wire color codes.

For the power transformer, the color coding is as follows:

Table 2: Power Transformer Terminal Wires Color Code

Primary winding	
0	Black
110V	White
0	Brown
110V	Orange
High voltage secondary winding	
200V	Red

0	Red/Black
Secondary winding for the tube filaments/heater	
6.3V	Green
0	Green/Black

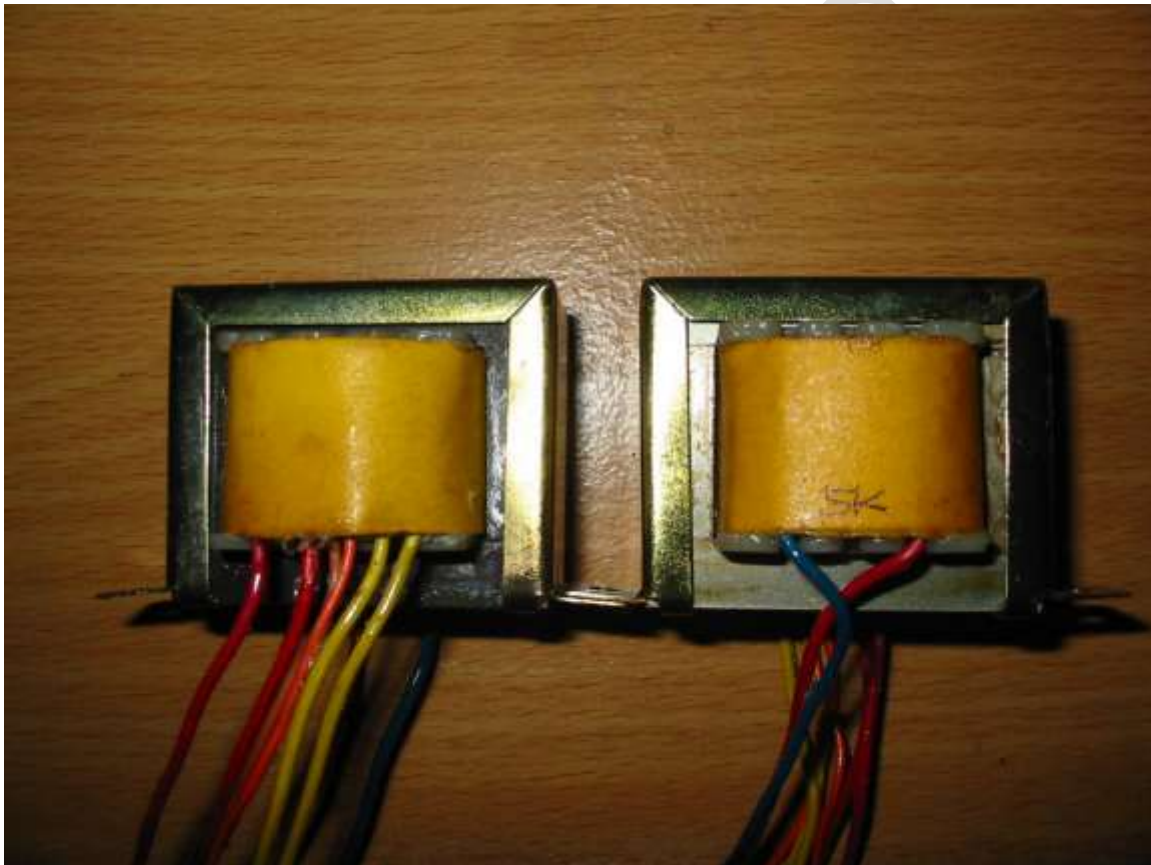

Figure 3: The Pair of Output Transformers

The following table lists the output transformer color coding.

Table 3: Output Transformer Terminal Wires Color Code

Primary winding	
B+	Red
Plate	Blue

Secondary winding	
0	Yellow/Black
8 ohms	Yellow
0	Orange/Black
32 ohms	Orange
0	Red/Black
300 ohms	Red

The Connectors – Headphone jack, RCA jacks, AC Inlet

The headphone jack supplied is a high-quality ¼” standard jack.



Figure 4: Headphone Jack

The kit is supplied with a pair of RCA jacks (one pair), headphone jack and a standard IEC connector (1 set).



Figure 5: A pair of RCA jacks, assembled

The gold plated, insulated RCA jacks when assembled. From bottom to top, please do take note of how the parts stack together. Refer to Figure 5 when the RCA is disassembled.

👁️ **The two white plastic washers though similar, are not the same.** One of these serves as the chassis insulation and has raised edges on the inner hole. This serves as the chassis insulation so that the RCA ground does not connect to the chassis hence the term “insulated RCA jack.”



Figure 6: A pair of disassembled RCA jacks

When assembling the RCA jack, the terminal connector goes to the body first, then the plastic washer with a guide hole, followed by the other plastic washer, and finally the locking nut.

The power connectors are high-quality Bulgin branded products, made up of a round AC Inlet Panel Plug and a corresponding round female connector. These connectors are rated for 3A at 250V.



Figure 7: AC Inlet Male Panel Plug



Figure 8: AC Female Connector

The Switches and Fuse Holder with Fuse

The Toggle Switches comes in two variants- one is DPDT (double pole, double throw) with six solder connectors, and the other is SPST (single pole, single throw) with two solder connectors.



Figure 9: Toggle Switch

The fuse holder is PCB-mount type and is small so that it can be hidden inside the chassis.



Figure 10: Fuse Holder

Recommended Tools

The basic tools needed to assemble this kit are shown in Figure 11.



Figure 11: Basic Tools

From left to right: Wire cutter (top), long-nosed pliers (bottom), soldering iron, solder sucker, cutter (top), soldering lead (bottom), a set of screwdrivers. The tools shown above are the actual tools I used in assembling the amplifier. I do not have fancy tools (I wish I have) nor do I find them a necessity. However, they make a good investment overtime if you plan to build more DIY projects.



Figure 12: A Digital Multi-meter and Accessories

A digital multi-meter with manual range function will be needed when making the resistance and voltage checks later on. Why manual range? Isn't it that auto-ranging is cool? In situations where you expect to measure a certain voltage range, say 360V, you don't want the reading "fluctuating" between milli volts and volts, so manual range is better.

The multi-meter can also be used to confirm the resistor values especially when you can't read resistor color codes.

Internal Layout Preview

The picture below shows how the transformers will be laid out inside the chassis. The transformers eat up most of the chassis space and this is the recommended layout. You will notice that there will be a space at the center of the chassis where the PSU board will be screwed on.

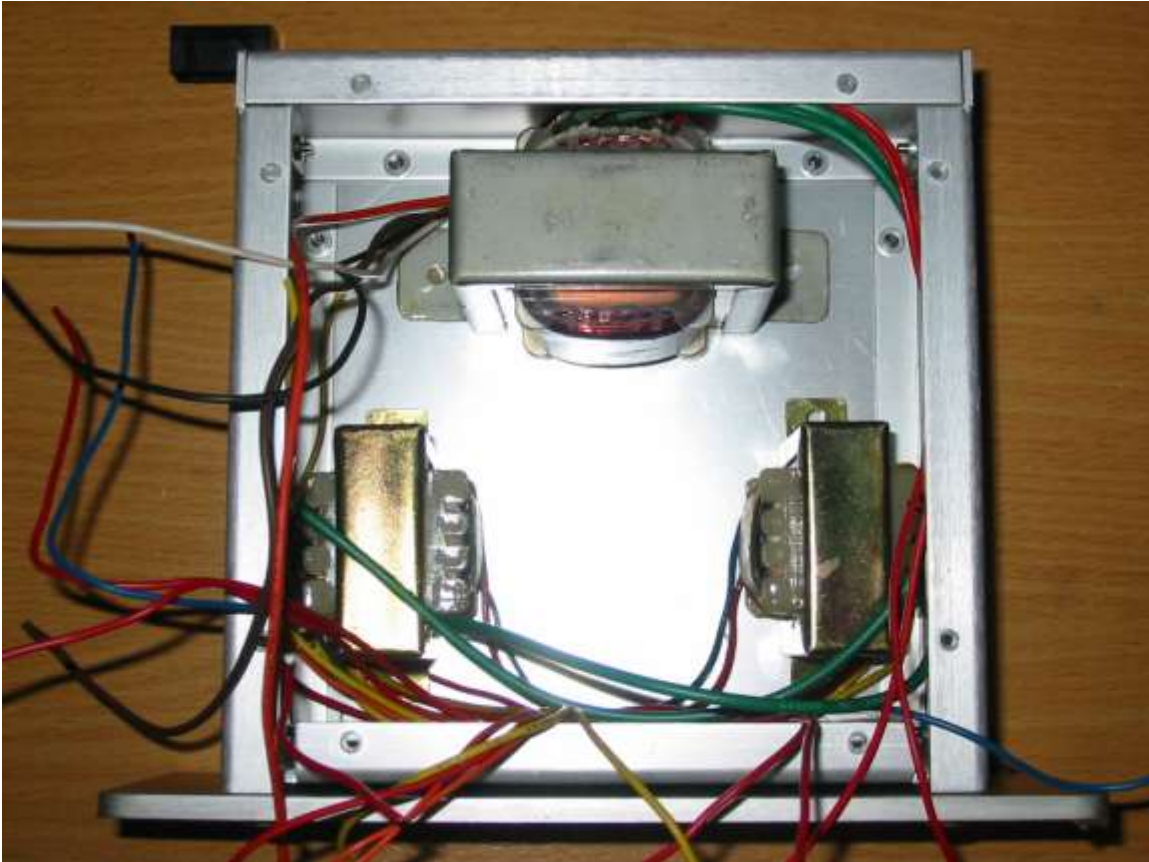

Figure 13: Mock Internal Layout

While the picture looks messy with all of those wires, you will be able to make it neat and tidy once the wires have been trimmed to the proper length.

Drilling Your Chassis

The chassis supplied with the kit is high quality aluminum in beautiful hairline finish. Prior to assembly, it is necessary to drill the mounting holes first.

① Read the Chassis Assembly section first to identify the different parts of the chassis. You don't need to assemble it now, but if you want to practice assembly, go ahead.

① There is no drill guide for the bottom plate of the chassis. Using the internal layout preview from the preceding figure, you must make the drill marks on your own. It is important that you make the drill marks when the chassis has been assembled.

Please take time to review the drill guide before you drill or punch your chassis. The attached drill guide is the recommended layout and is the basis for the descriptions in this section. Should you wish to change the layout, be sure to make the necessary adjustments.

Please consult the following drill guide for the suggested drill points on the chassis panels.

① Please note that your aluminum chassis has an “inside” front panel and a Faceplate. The following drill guide is for the Faceplate. If you wish to use the inside front panel, you have to make the necessary drill guide based on the Faceplate drill guide.

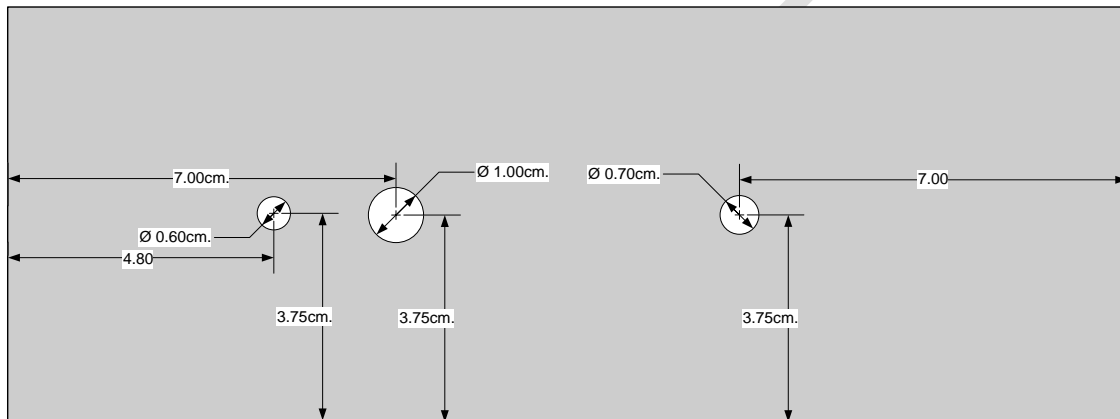

Figure 14: Faceplate Drill Guide

From left to right are the impedance selector switch hole, headphone socket hole, ALPS potentiometer hole.

① The ALPS potentiometer has a guide pin, which will require a 0.3cm (3mm) hole, 0.5cm (5mm) from the center. It is not included in the drill guide so that you can rotate the ALPS in any position. The front panel is thick, and the guide hole must be drilled from the inside of the panel. The drill depth is 0.4cm (4mm).

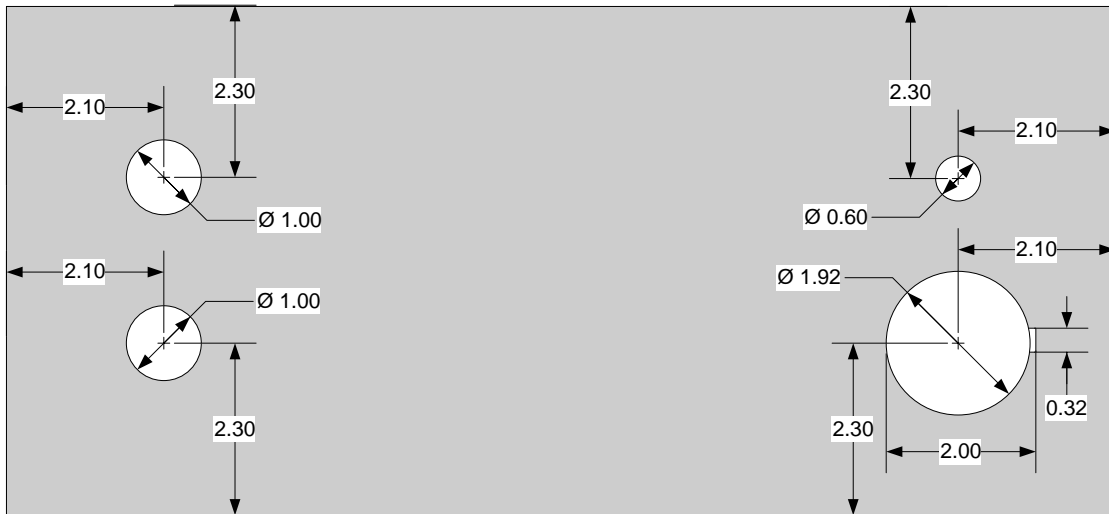

Figure 15: Back Panel Drill Guide

From left to right are the two RCA holes for the input, main power switch hole (top right), AC Inlet connector hole (bottom right).

① Please take note of the 0.32cm (3.2mm) notch for the Male AC Inlet. It is necessary so that the connector will not rotate while plugging or unplugging the Female connector.

DRAFT

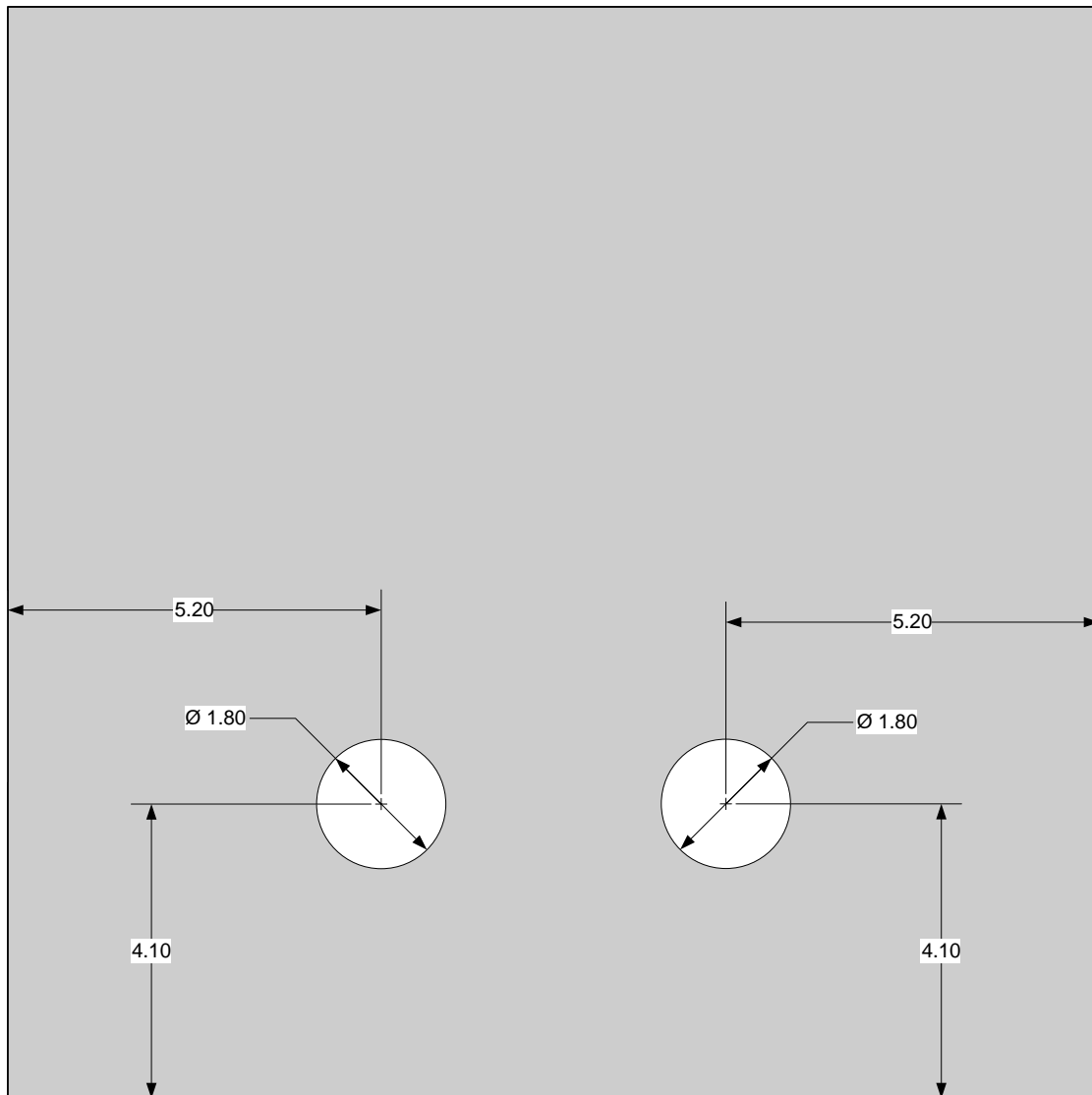

Figure 16: Top Panel Drill Guide

① The top panel holes are for the two 9-pin tube sockets. There is no drill guide for the socket mounting screws. Once you have drilled the socket holes, mount the socket and align the socket fastening holes vertically with pin 1 of the socket facing the front. You then mark the point for drilling the holes for the socket fastening screws. Do this for both sockets.

Chassis Assembly

Once the necessary mounting holes have been drilled, you are ready to assemble the chassis. Consult the picture below on how the chassis will look like when properly assembled.

The top and bottom panel are completely interchangeable in their use. The same can be said for the left and right panels.



Figure 17: Assembled Chassis sans Top Cover

Do note that this picture is for visual guide only and as such, there are no mounting holes visible on the panels. Once you assemble your own, it will look similar but yours will have the mounting holes.

Please be aware of the Faceplate (the panel widest) and the “inside” front panel as this will affect your drilling strategy for the controls visible and to be mounted in front.

In addition, you have the option of using the panel with ventilation holes as either top or bottom panel. For best ventilation of the power transformer, I would suggest that the panel with ventilation holes be used on top.



Figure 18: Assembled Chassis, a Different View

The best thing about this chassis is that all panels (top, bottom, left, right, back, front) are totally removable for easy access during assembly.



Figure 19: Assembled Chassis with Top Cover, unscrewed

Mechanical Assembly

The rear of the chassis (shown at the top most part of the illustration) shows, from right to left, pair of RCA Jack; AC Inlet Connector; and Toggle Switch (Power).

The middle part of the illustration represents the top of the chassis and shows the mounting designation for the transformers.

The front side of the chassis (shown at the bottom part of the illustration) from left to right, shows the mounting holes for the Toggle Switch (Impedance selector- 32/300 ohms), Headphone Jack, and Volume Control.

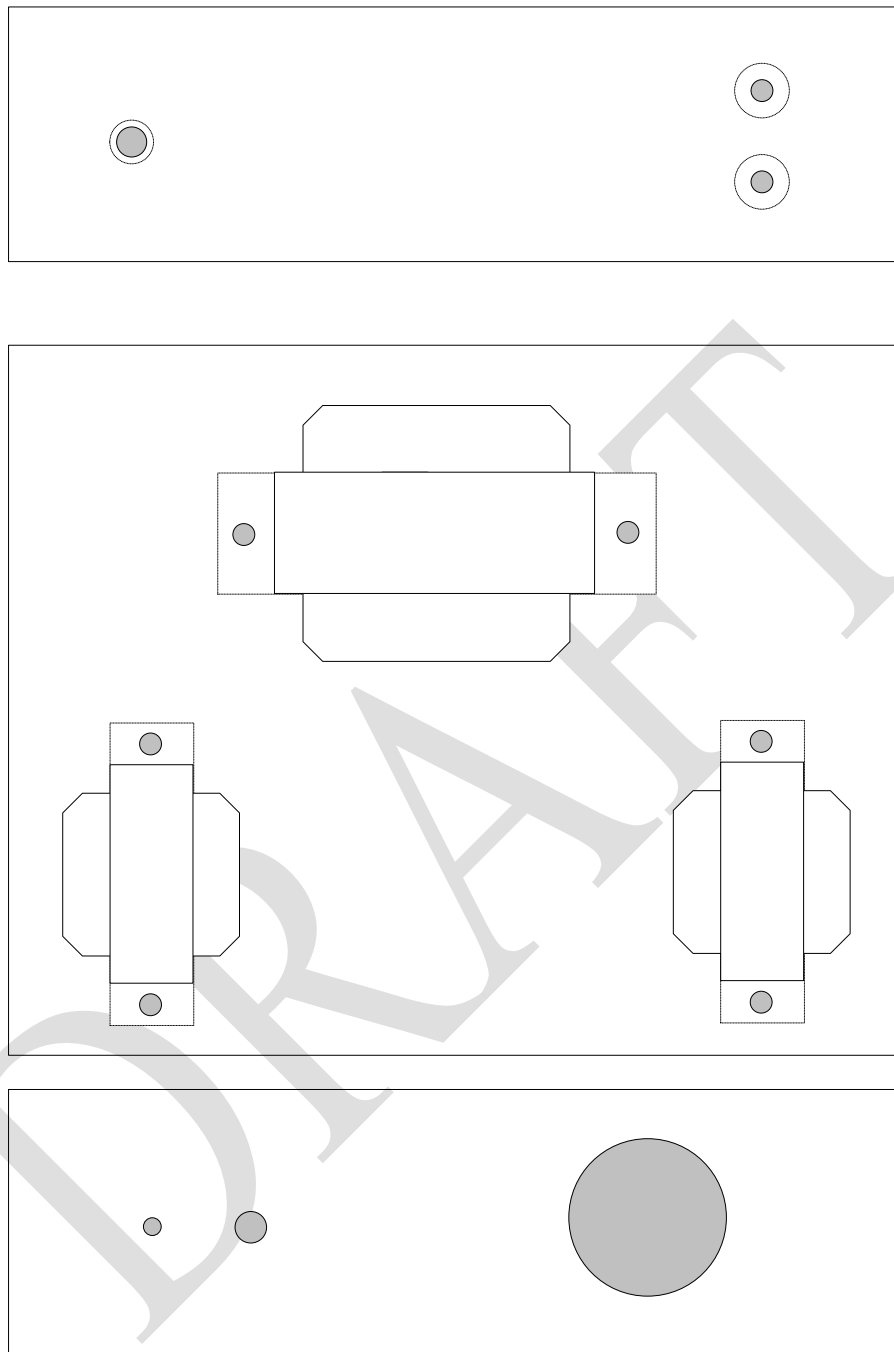

Figure 20: The Chassis, Top View

Installing the RCA Input Jacks

Locate and identify the pair (one Red, one Black) of RCA jacks from your parts inventory.

- Unscrew the locking nut and remove the white washer from the RCA jack. Set aside.
- Insert the RCA jack and the guide washer from the inside of the chassis
- Insert the white washer back and screw the locking nut securely onto the RCA jack
- Repeat for the other channel.

Installing the AC Inlet Connector

Locate and identify the supplied AC Inlet connector from your parts inventory.

- Unscrew the plastic locking nut from the AC Inlet connector. Set aside.
- Align the AC Inlet connector according to the round hole provided at the rear of the chassis.
- Insert from the outside of the chassis and securely fasten the AC Inlet connector in place using the plastic locking nut

Installing the Power Switch

Locate and identify the Toggle Switch to be used for the main power connections.

- Unscrew the locking nut and remove the metal washer from the switch body. Set aside.
- Insert the switch body, from the inside of the chassis, into the hole found at the back of the chassis.
- Orient the switch so that when the lever is up, it is in the “ON” position.
- Insert the metal washer back and screw the locking nut securely onto the switch body.

Installing the Fuse Holder

Locate and identify the black Fuse Holder from your parts inventory.

- Unscrew the locking nut and remove the metal washer from the Fuse Holder body.
- Insert the Fuse Holder into the rear of the chassis
- Insert the metal washer back and screw the locking nut securely onto the Fuse Holder body.

Installing the Impedance Switch

Locate and identify the Toggle Switch (6-pins) to be used for the impedance selector.

- Unscrew the locking nut and remove the metal washer from the switch body.

- Insert the switch body, from the inside of the chassis, into the hole found in front of the chassis.
- Insert the metal washer back and screw the locking nut securely onto the switch body.

Installing the Headphone Jack

Locate and identify the Headphone Jack from your inventory.

- Unscrew the locking nut and remove the washer from the Headphone Jack body.
- Insert the switch body, from the inside of the chassis, into the hole found in front of the chassis.
- Insert the washer back and screw the locking nut securely onto the Headphone Jack body.

Installing the Volume Control

Locate and identify the ALPS Volume Potentiometer (Blue) from your inventory.

- Unscrew the locking nut and remove the washer from the potentiometer body.
- Insert the switch body, from the inside of the chassis, into the hole found in front of the chassis.
- Insert the washer back and screw the locking nut securely onto the potentiometer body.

Installing the Tube Sockets and Terminal Strip

There are two 9-pin sockets provided in the kit.

- ① The 9-pin sockets are mounted from the top of the chassis.
 - Mount the two (2) 9-pin sockets on the holes provided in the chassis. Make sure that pin 1 is facing the front of the chassis.
 - Use the supplied M3 nuts and bolts to secure the socket in place.

The terminal strips are mounted at the bottom of the chassis using the screws that holds the 9-pin sockets into place. The terminal strip mounting holes are secured using the screws closest to pin 4 of both tube sockets.

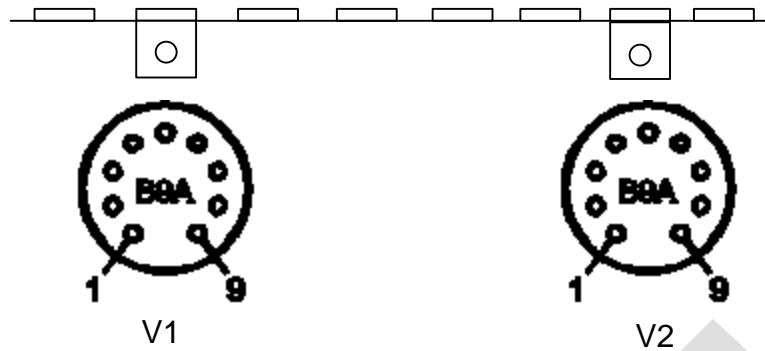

Mounting the Transformers

⚠ Warning: The transformers are heavy. Please take care when mounting these to the chassis and make sure not to accidentally get hurt.

The transformers are mounted inside the chassis.

Locate the Power Transformer and orient the terminal wires to face the back of the chassis.

- Align the transformer mounting holes onto the chassis mounting holes.
- Securely mount the transformer using the M3 nuts and bolts with washers provided in the kit. The washers are used on both top and bottom to “sandwich” the transformer and chassis.

Locate the Output Transformers AC-OPT-201 and orient it so that the side with most wires (the Secondary side) is facing the chassis.

- Align the transformer mounting holes onto the chassis mounting holes.
- Securely mount the transformer using the M3 nuts and bolts with washers provided in the kit. The washers are used on both top and bottom to “sandwich” the transformer

How to Attach an Optional Feet

Your chassis is supplied with four (4) rubber feet that you can screw from the bottom of the chassis.

Electrical Assembly

Wiring the Main Circuit

The following illustration shows the wiring diagram for the main circuit. This is the bottom view.

Please note the Single Ground Point (SPG) on the terminal strip identified by a BLACK dashed circle. It is important that all ground wires be soldered at this point to minimize hum and noise. To the immediate left of the SPG is the B+ point identified by a RED dashed circle.

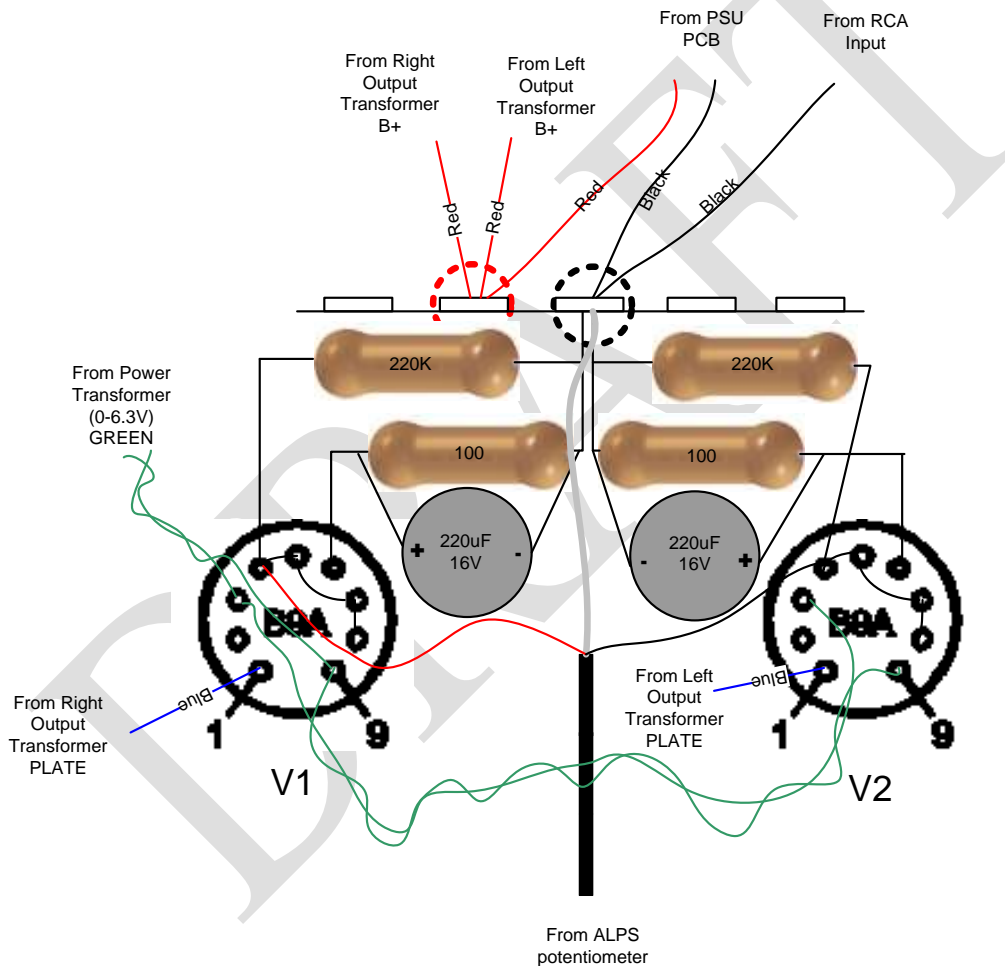

Figure 21: Main Circuit Wiring

The first step is to wire up the heater (filament).

- Cut to size (about 6 inches) a pair of GREEN hook up wire long enough to reach V2's tube socket from V1. Mark one of the wires with a black marker, making it GREEN/BLACK.

- Strip both ends and twist the hook up wires.
- Solder the GREEN hookup wire to V1-3 and the GREEN/BLACK to V1-9.
- Solder the other end of the GREEN hookup wire to V2-3 and the other end of the GREEN/BLACK wire to V2-9.

Identify the GREEN and GREEN/BLACK (filament winding) terminal wires from the power transformer. Check with the transformer specifications once more and you will see that we are using the 0 (GREEN/BLACK) and 6.3V (GREEN) taps.

- Cut to size, strip the ends, and twist the GREEN and GREEN/BLACK terminal wires and solder the GREEN wire to V1-2 and the GREEN/BLACK wire to V1-9.

You are now done wiring the heaters of the tubes.

Here are the assembly instructions for wiring the Main Circuit:

- Start with the tube socket V1. Using a very short wire, tie up pins 4, 5, 7, and 8.
- Do the same for the socket on the V2.
- Identify one 100 ohm resistor. Bend the resistor lead as appropriate and solder one end to V1-6, and the other end to the SPG.
- Identify the other 100 ohm resistor. Bend the resistor lead as appropriate and solder one end to V2-6, and the other end to the SPG.
- Identify one 220K ohm resistor. Bend the resistor lead as appropriate and solder one end to V1-4, and the other end to the SPG.
- Identify the other 220K ohm resistor. Bend the resistor lead as appropriate and solder one end to V2-4, and the other end to the SPG.
- Identify the two 220uF 16V electrolytic capacitors. Cut the leads appropriately and solder to each 100 ohm resistor in parallel. Make sure that the negative (-) ends are connected to the SPG.

 Review the polarity of these two capacitors. If you mount them in reverse and applied power, the capacitor might blow up and emit hazardous fumes.

You are now done with the passive parts.

The next part is to connect the primary of the output transformers. Identify the primary winding of the output transformers- RED for B+ and BLUE for Plate.

- Cut to size, strip the ends, and solder the Right output transformer BLUE wire to V1-1.
- Cut to size, strip the ends, and solder the Right output transformer RED wire to the terminal strip B+ point.
- Cut to size, strip the ends, and solder the Left output transformer BLUE wire to V2-1.

- Cut to size, strip the ends, and solder the Left output transformer RED wire to the terminal strip B+ point.

You are now done wiring the Main Circuit assembly. Relax, have a drink then come back and review your work.

It should look similar to this:



Checkpoint

Make sure you have good solder on the wire leads. We are going to measure the resistance in the circuit.

Take your DMM, set it to resistance and attach the black test lead to the SPG. Use the red test lead and touch the following:

V1-4 – should read 220K ohms

V1-6 – should read 100 ohms

V2-4 – should read 220K ohms

V2-6 – should read 100 ohms

If you got the readings right, you may proceed to the next section. If not, go back and re-check your connections.

Wiring the Front and Back Panel Connectors and Switches

The next step requires working with more wires and more soldering. You will be wiring the front and back panels- working from the front panel to the back. This step is the most tedious of all.

Ready?

- ☞ Identify both output transformers' secondary windings.
 - Bunch up the ORANGE/BLACK and RED/BLACK wires from both transformers- a total of four (4) wires.
 - Strip the ends and twist the exposed ends together.
 - Solder the ends to the Common terminal of the headphone jack.
 - Locate the pre-cut WHITE hookup wire. Solder one end to the Left Center pin of the Toggle Switch. Solder the other end to the Left Channel terminal of the headphone jack.
 - Locate the pre-cur RED hookup wire. Solder one end to the Right Center pin of the Toggle Switch. Solder the other end to the Right Channel terminal of the headphone jack.

DRAFT

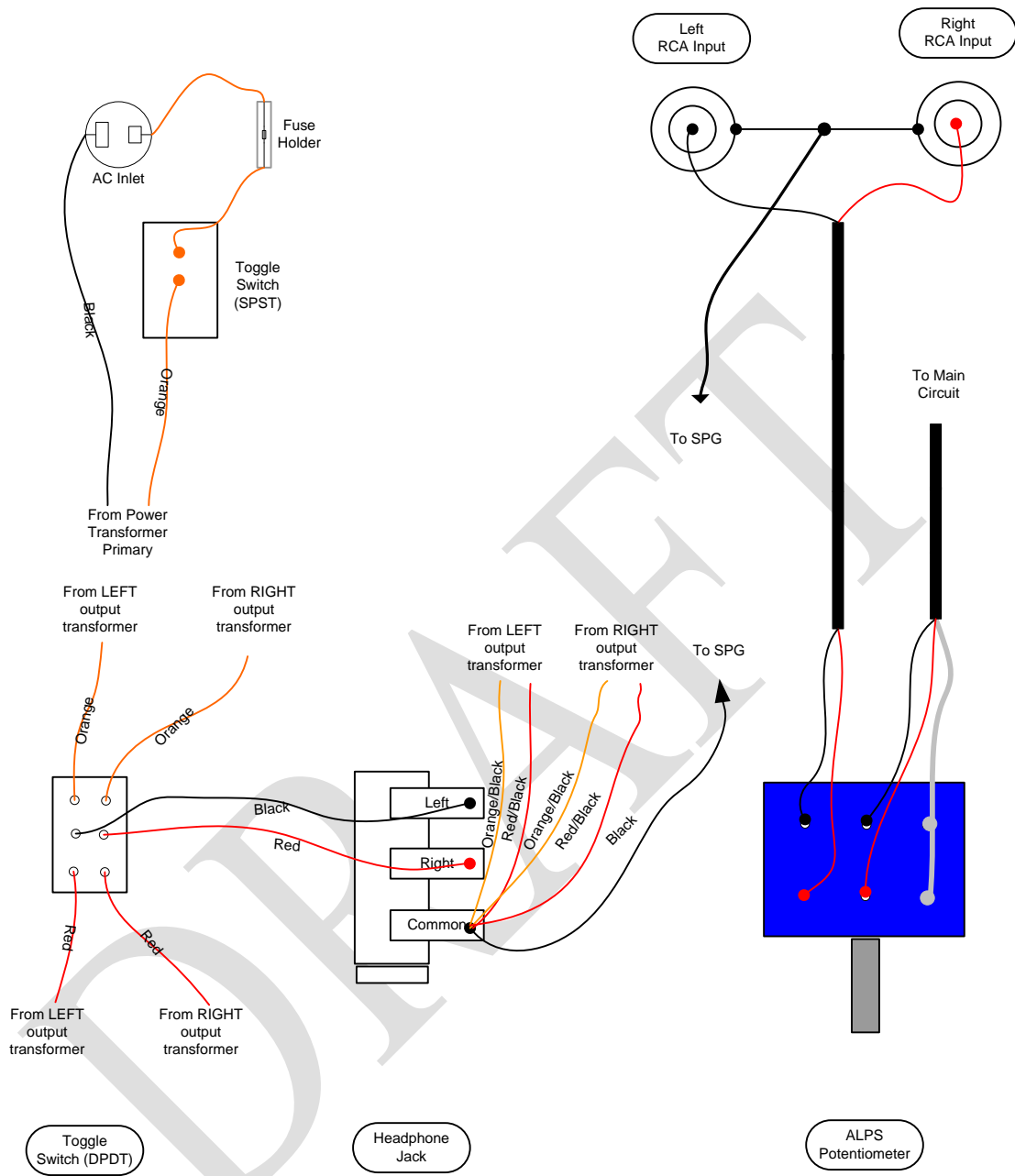

Figure 22: Front/Back Panel Wiring

👁 Identify the Left Output Transformer's 32 ohm winding (ORANGE) and 300 ohm winding (RED).

- Strip the ends of the ORANGE and RED wires.
- Solder the ORANGE wire to the Left upper terminal of the Toggle Switch.
- Solder the RED wire to the Left lower terminal of the Toggle Switch.

👁 Identify the Right Output Transformer's 32 ohm winding (ORANGE) and 300 ohm winding (RED).

- Strip the ends of the ORANGE and RED wires.
- Solder the ORANGE wire to the Right upper terminal of the Toggle Switch.
- Solder the RED wire to the Right lower terminal of the Toggle Switch.

Checkpoint

Stop and double check your wiring. The RED and ORANGE wires from the output transformers may confuse you. Refer to the diagram above in verifying your connections.

At this point, you have completed wiring the output stage, and will look similar to this:



The next part is to wire the input stage, starting with the RCA connectors.

- Connect the two RCA ground connectors via short solid wire.
- Cut the BLACK hookup wire to an appropriate length (from the RCA to the SPG) and strip both ends.
- Solder one end to one of the RCA ground connector (or to the middle of the short wire, as shown in the diagram)

- Solder the other end of the BLACK hookup wire to the SPG.
- Identify the shielded cable, and cut to an appropriate length (from the RCA to the ALPS potentiometer).
- Strip both ends exposing the inner conductors then cut off the shield.
- Strip the ends of the RED and WHITE conductor.
- On one end, solder the WHITE conductor to the center connector of the LEFT RCA. Then solder the RED conductor to the center connector of the RIGHT RCA.
- On the other end solder the WHITE conductor to the Left pin of the ALPS farther away from the chassis. Then solder the RED conductor to the Left pin of the ALPS closer to the chassis.
- Identify the shielded cable, and cut to an appropriate length (from the ALPS potentiometer to V1-4 and V2-4).
- Strip both ends exposing the inner conductors then twist the shield tightly.
- Strip the ends of the RED and WHITE conductor.
- On one end, solder the WHITE conductor to the Center pin of the ALPS farther away from the chassis. Then solder the RED conductor to the Center pin of the ALPS closer to the chassis.
- Solder the shield to both Right pin of the ALPS.
- On the other end of the shielded wire, solder the RED conductor to V1-4, then solder the WHITE conductor to V2-4.
- Solder the shield to the SPG. This wire should be as short as possible.

Checkpoint

Stop and double check your wiring. Refer to the diagram above in verifying your connections.

Ok, it seems you're doing fine if you reach this point and you can still think straight.

The final part is to wire the AC input connection. Take a breather before you proceed.

- 👁️ Identify the Power Transformer PRIMARY winding.
 - Locate the WHITE (0V) and ORANGE (200V) from the Power Transformer primary.
 - Strip both ends.
 - Solder the WHITE wire to the NEUTRAL pin of the AC Inlet.
 - Solder the ORANGE wire to the Center pin of the Toggle Switch.

- Cut to appropriate length the ORANGE hookup wire and strip both ends.
- Solder one end of the ORANGE hookup wire to the other pin of the Toggle Switch.
- Solder the other end of the ORANGE hookup wire to one of the pins of the Fuse Holder.
- Cut to appropriate length the ORANGE hookup wire and strip both ends.
- Solder one end of the ORANGE hookup wire to the other pin of the Fuse Holder.
- Solder the other end of the ORANGE hookup wire to the LIVE pin of the AC Inlet.

Checkpoint

Stop and double check your wiring. Refer to the diagram above in verifying your connections. At this point you have completed the wiring of the Input/Output/Power section of your kit.

Wiring the Power Supply Unit (PSU)

The next step is to wire in the Power Supply Unit.

- Identify the Power Transformer high voltage secondary wires, colored RED
- Strip both ends.
- Solder one end to one of the AC IN holes on the PSU board.
- Solder the other end to the other AC IN hole on the PSU board.
- Cut to appropriate length and strip both ends of a RED hookup wire.
- Solder one end to the B+ hole in the PSU board.
- Solder the other end to the B+ terminal in the Main Circuit.
- Cut to appropriate length and strip both ends of a BLACK hookup wire.
- Solder one end to the GND hole in the PSU board.
- Solder the other end to the SPG terminal in the Main Circuit.

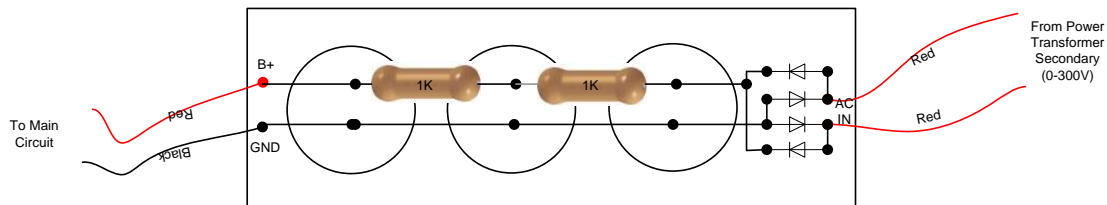

Checkpoint

Wow! If you've come this far, you are now a DIY prince ☺

The internal wiring will be similar to this:

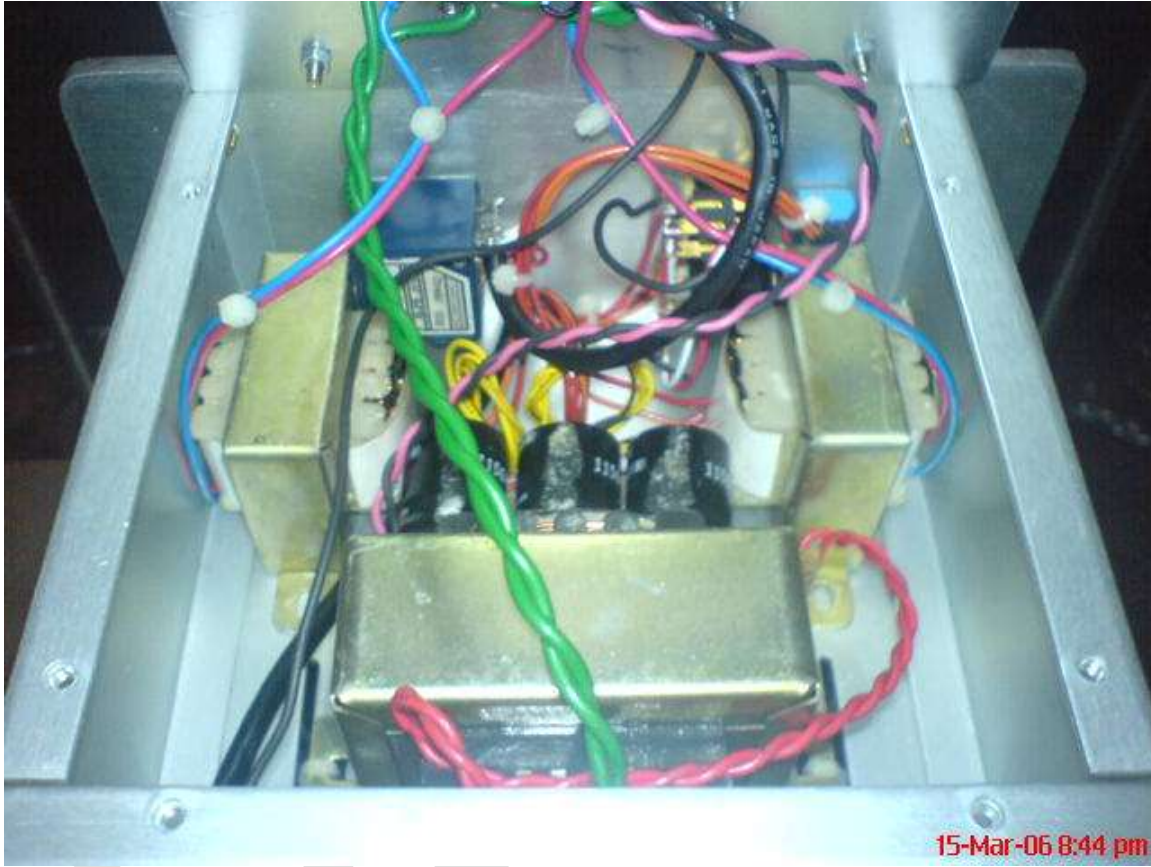

Powering Up

At this point, you are ready to apply power to your completed kit.